

## CATALOGUE

**PU / PIR Foam & Ular Support**

**Steel Shoe : Chiller Shoe, Anchor Shoe, Steam Shoe, Guide Shoe**

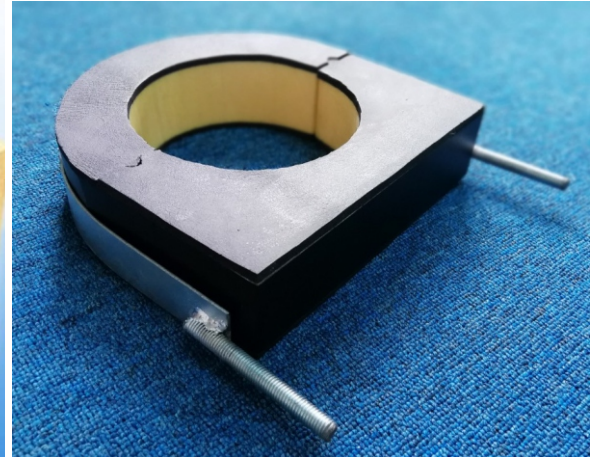

Version : 01-2024

**CÔNG TY TNHH MTV PRODETECH  
PRODETECH ONE MEMBER CO., LTD**

Địa chỉ : Nhà B5-20 Vinhomes Gardenia Hàm Nghi, P. Cầu Diễn, Q. Nam Từ Liêm, TP Hà Nội

Nhà máy : Thôn 5, Xã Phú Cát, Huyện Quốc Oai, TP Hà Nội

Website : [www.prodotech.vn](http://www.prodotech.vn)

Email : [info@prodotech.vn](mailto:info@prodotech.vn)

Hotline : 0913 5540 030



## Table of Contents

<b>NO</b>	<b>INDEX</b>	<b>CONTENS</b>	<b>PAGES</b>
<b>1</b>	<b>A</b>	<b>Introduction of Manufacture Profile</b>	<b>02</b>
<b>2</b>	<b>B</b>	<b>Bussiness Registration Certificates</b>	<b>05</b>
<b>3</b>	<b>C</b>	<b>ISO Quality Managanents</b>	<b>06</b>
<b>4</b>	<b>D</b>	<b>Catalogue</b>	<b>07</b>
<b>5</b>	<b>E</b>	<b>Test Result</b>	<b>27</b>
<b>6</b>	<b>F</b>	<b>Material CO-CQ</b>	<b>30</b>
<b>7</b>	<b>G</b>	<b>Actual Production Photos</b>	<b>31</b>
<b>8</b>	<b>H</b>	<b>Typical project</b>	<b>32</b>
<b>9</b>		<b>End page</b>	<b>38</b>

## A. Introduction of Manufacture Profile

### Introduction

**Company name :** CÔNG TY TNHH MTV PRODETECH  
**International name :** PRODETECH ONE MEMBER COMPANY CO., LTD  
**Abbreviations :** PRODETECH ., LTD  
**Office address :** Shophouse B5-20 Vihomes Gardenia Ham Nghi, Cau Dien Ward, Nam Tu Liem District, Hanoi city, Vietnam.  
**Factory address :** Ward 5, Phu Cat Commune, Quoc Oai District, Hanoi city, Vietnam.  
**Website :** [www.prodetechn.vn](http://www.prodetechn.vn)      **Email :** [info@prodetechn.vn](mailto:info@prodetechn.vn)      **Hotline :** 0913 554 030

#### BUSINESS PHILOSOPHY

Quality is the vitality not only of enterprises but also of the whole society.  
Always build trust and bring satisfaction to customers (including internal customers).  
PRODETECH'S goal is to provide customers with cost-effective and efficient solutions and services. See customer trust as the biggest product of the business

#### MISSION

Continue to promote the company spirit: operate honestly, professionally and friendly, provide optimal solutions to customers, provide creative working conditions for employees, and protect the environment.

#### MANAGEMENT SYSTEM

We has developed and operated with its management system which incorporates Quality- Environment Management.  
ISO 9001-2015 - Quality Management Requirements  
ISO 14001-2015 - Environmental Management System

#### VISION

To ensure monitoring and improve the quality of the company's electromechanical products in Vietnam in general and Southeast Asia in particular, we actively promote computerized management and improve staff qualifications. members, updating new production equipment, creating competitiveness for products to meet strict customer requirements.

## History of formation and Development

1996

**Thành lập CÔNG TY TNHH PHÁT TRIỂN CNTH & TM HOÀ BÌNH (DETI CO., LTD)**  
Đầu tư xây dựng Tòa nhà VP ATATA tại KCN Yên Sơn - Quốc Oai - HN

2005

**Thành lập CÔNG TY CỔ PHẦN QUỐC TẾ ZEUS**  
Tổng thầu EPC cho nhà máy Nhật Bản - Thái Lan tại Việt Nam

2008

**Thành lập CÔNG TY CP PRODETECH**  
Đầu tư xây dựng nhà máy sản xuất: Thang máng cáp, Tủ điện, Ống gió, Cửa gió, Van gió và phụ kiện.

2009

**Đầu tư nhà máy sản xuất bảo ôn thương hiệu ATATA**  
Dây chuyền sản xuất: bảo ôn cách nhiệt tấm, ống, tấm xốp trứng và xốp trứng PU Foam, phụ kiện cho gioăng đệm ống gió, gối đỡ cách nhiệt PU Urethan...  
Thành lập chi nhánh ATATA tại Myanmar và Campuchia

2013

**Đầu tư nhà máy tại KCN Lê Minh Xuân - TP. HCM phục vụ thị trường Miền Nam**

2017

**CHUYỂN ĐỔI HÌNH THỨC CÔNG TY TNHH MTV PRODETECH**  
Đầu tư nhà máy sản xuất ống gió tại Phú Cát - Thạch Thất - TP. Hà Nội

2018

**ĐẦU TƯ VÀ MỞ RỘNG 02 NHÀ MÁY SẢN XUẤT**  
Mở rộng nhà máy Phú Cát sản xuất băng dính  
Xây dựng nhà máy băng cuốn tại Quất Động - Thường Tín - TP. Hà Nội

2023

**ĐẦU TƯ NHÀ MÁY SẢN XUẤT BẢO ÔN NHIỆT NÓNG**  
Xây dựng dây chuyền sản xuất: bông khoáng, bông thủy tinh, bông gốm tại Hòa Sơn - Lương Sơn - Hòa Bình

2025

**Thành lập CÔNG TY TNHH ÂM THANH CÔNG NGHỆ CAO (HIENSOUND CO., LTD)**  
Thành lập VPDD T18-18 THE MANHATTAN, KĐT VINHOMES GRANDPARK - TP. THỦ ĐỨC - TP. HCM  
ĐẦU TƯ XÂY DỰNG KHO HÀNG TẠI LONG AN

## ORGANIZATION CHART

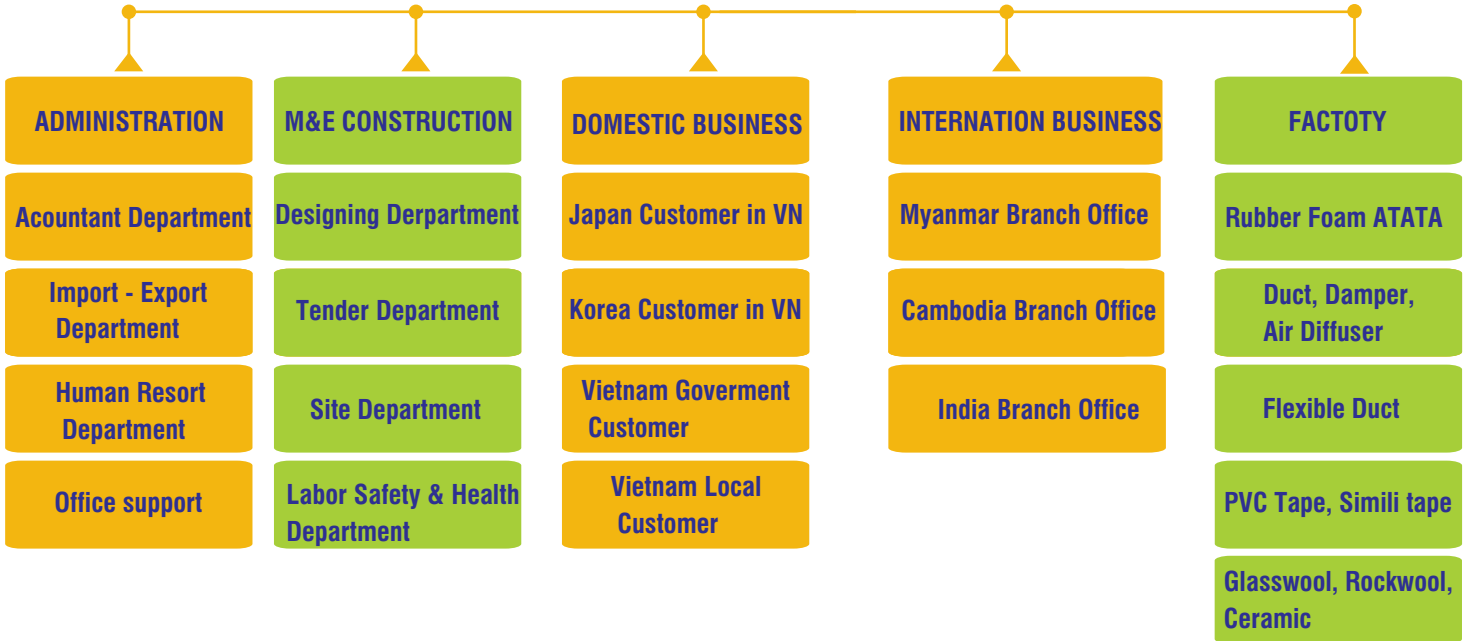

## FINANCIAL CAPACITY

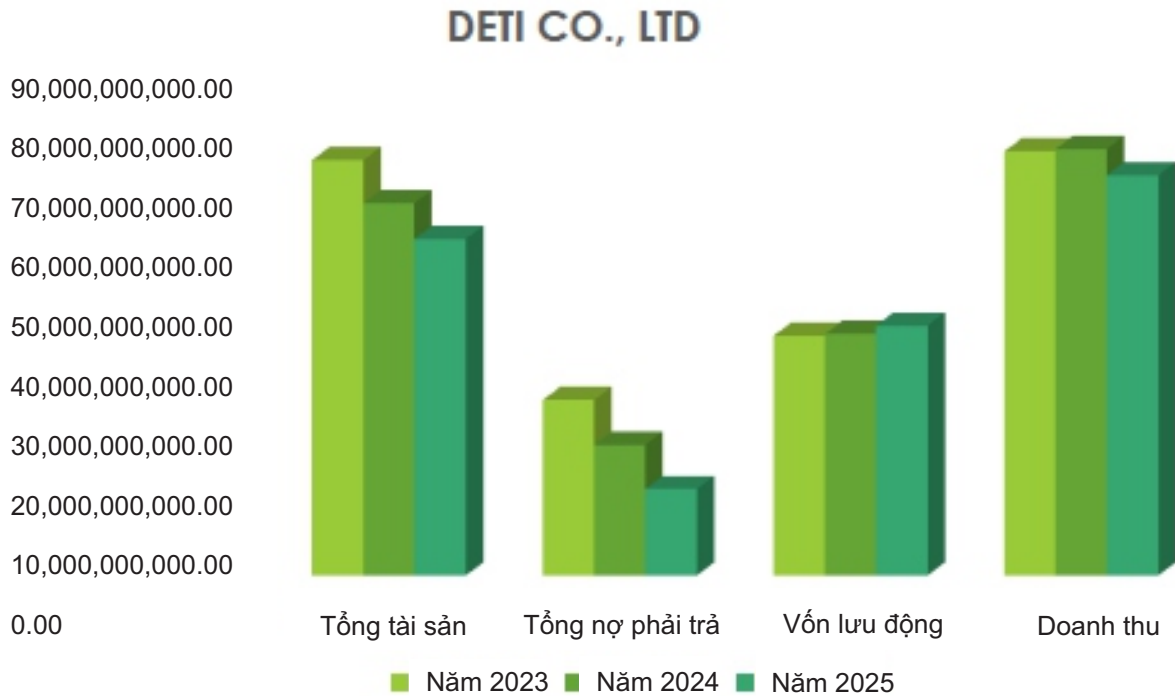

Summary of financial capacity data for the last 3 years 2023,2024,2025 :

SỞ TÀI CHÍNH THÀNH PHỐ HÀ NỘI  
PHÒNG ĐĂNG KÝ KINH DOANH VÀ  
TÀI CHÍNH DOANH NGHIỆP

CỘNG HÒA XÃ HỘI CHỦ NGHĨA VIỆT NAM  
Độc lập - Tự do - Hạnh phúc

**GIẤY CHỨNG NHẬN ĐĂNG KÝ DOANH NGHIỆP  
CÔNG TY TRÁCH NHIỆM HỮU HẠN MỘT THÀNH VIÊN**

**Mã số doanh nghiệp: 0102696636**

*Đăng ký lần đầu: ngày 19 tháng 03 năm 2008*

*Đăng ký thay đổi lần thứ: 14, ngày 19 tháng 08 năm 2025*

**1. Tên công ty**

Tên công ty viết bằng tiếng Việt: CÔNG TY TNHH MỘT THÀNH VIÊN  
PRODETECH

Tên công ty viết bằng tiếng nước ngoài: PRODETECH ONE MEMBER COMPANY  
LIMITED

Tên công ty viết tắt: PRODETECH., LTD

**2. Địa chỉ trụ sở chính**

*Nhà số B5-20, khu đô thị Vinhomes Gardenia, đường Hàm Nghi, Phường Từ Liêm,  
Thành phố Hà Nội, Việt Nam*

Điện thoại: 02432009151/02432009152

Số Fax:

Thư điện tử: [info@prodetech.vn](mailto:info@prodetech.vn)

Website: [prodetech.vn](http://prodetech.vn)

**3. Vốn điều lệ : 50.000.000.000 đồng.**

*Bằng chữ: Năm mươi tỷ đồng*

**4. Thông tin về chủ sở hữu**

Họ, chữ đệm và tên: NGUYỄN XUÂN TÀI

Giới tính: *Nam*

Ngày, tháng, năm sinh: 26/11/1979

Quốc tịch: *Việt Nam*

Số định danh cá nhân: 001079026152

Địa chỉ liên lạc: *Cụm 6, Xã Ô Diên, Thành phố Hà Nội, Việt Nam*

**5. Người đại diện theo pháp luật của công ty**

\* Họ, chữ đệm và tên: NGUYỄN XUÂN TÀI

Giới tính: *Nam*

Ngày, tháng, năm sinh: 26/11/1979

Quốc tịch: *Việt Nam*

Số định danh cá nhân: 001079026152

Chức danh: *Chủ tịch Công ty*

Địa chỉ liên lạc: *Cụm 6, Xã Ô Diên, Thành phố Hà Nội, Việt Nam*

**KT. TRƯỜNG PHÒNG  
PHÓ TRƯỞNG PHÒNG**



**Nguyễn Hữu Lương**



## CHỨNG NHẬN

Hệ thống quản lý của

### CÔNG TY TNHH MỘT THÀNH VIÊN PRODETECH

**Nhà số B5-20, khu đô thị Vinhomes Gardenia, đường Hàm Nghi, Phường Cầu Diễn, Quận Nam Từ Liêm, Thành phố Hà Nội, Việt Nam**

Tham chiếu Phụ lục Giấy chứng nhận ban hành ngày 27.07.2025 cho các địa điểm chứng nhận.

Điều hành

### Hệ thống quản lý chất lượng

Phù hợp yêu cầu tiêu chuẩn

### ISO 9001:2015

Phạm vi cấp chứng nhận

### Sản xuất và cung cấp thang cáp, máng cáp, ống gió, cửa gió và tủ điện

Mã EA: 17 & 19

Số chứng nhận: VN-10141-QMS

Ngày ban hành chứng nhận lần đầu: 21.04.2025

Ngày cấp giấy chứng nhận hiện tại: 27.07.2025

Ngày ban hành giấy chứng nhận: 27.07.2025

Ngày chứng nhận hết hiệu lực: 20.04.2028

Đại diện Tổ chức Chứng nhận DAS  
Việt Nam xác nhận bản dịch



**Đăng ký bởi:**

Tập đoàn Quản lý Bền vững SMG, Số 78 phố George, thành phố Ottawa, tỉnh bang Ontario, K1N5W1 Canada

Chứng chỉ này tuân theo Điều khoản và Điều kiện Chứng nhận của SMG và vẫn là tài sản của SMG và phải được trả lại cho SMG theo yêu cầu của SMG.

# D. CATALOGUE

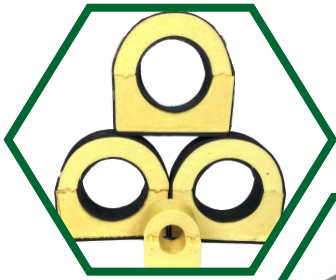

PU foam square support

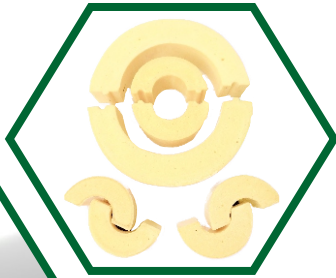

PU foam circle support

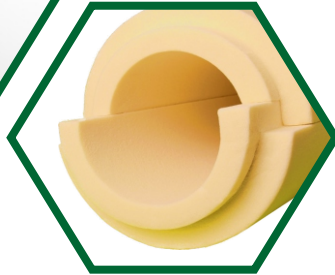

PU foam 360 degree support

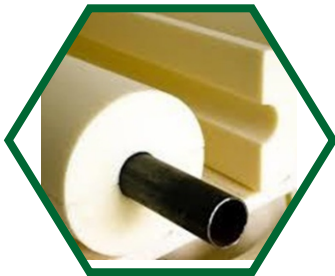
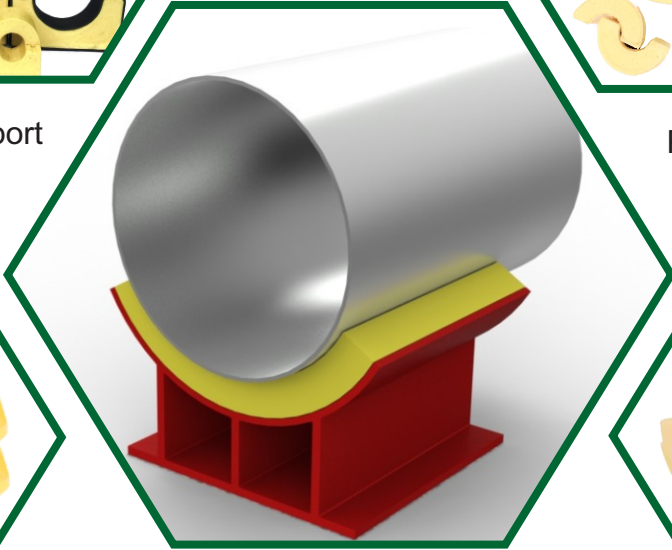

PIR foam support

## Steel shoe



Guide shoe

**GS**



Anchor shoe

**AS**



Restrains shoe

**RS**



Cùm Ular

**UL**

# URETHAN SHOE & STEEL SHOE

## I. POLYURETHAN FOAM ( PU FOAM)

### - Cold Shoe: Urethan Shoe, Chiller Shoe

A Cold Shoe or Chiller Shoe support utilizes Polyurethane foam as both an insulating material and a load bearing member of the support. This allows the pipe surface to be completely encapsulated by the foam component without relying upon a structural member to support the load.



**PU foam Square support**

**Code : PUS - aD x bT x L**



**PU foam Circle support**

**Code : PUC - aD x bT x L**



**PU foam 120 / 360 Degree support**

**Code : PUD - aD x bT x L**

### TECHNICAL SPECCIFICATIONS

Reliability in terms of use:	PU Foam can withstand temperatures from -200°C to 100°C
The ability to absorb water :	PU Foam with low gas permeability.
The fire :	Like all other organic original insulation, PU Foam is flammable. However, the ability and the flow rate can be adjusted to fit each building. Fighting capabilities of the panel can be significantly reduced by surface material, for example steel sheet surface...
Density	At the rate of 130kg/m <sup>3</sup> , the volume of polyurethane in PU Foam bearing is about 3%, the remaining 97% of the foam block is air trapped in the foam structure makes it have low heat transfer.
The deformaon	Bearing foam are mixing will swell filled area containing the original. It is be-cause of this characteristics that PU Foam easily be manipulated into a fixed shape ( square round pillows foam consists of two pieces of yin and yang) and convenient in transportation and installion.



# URETHAN SHOE & STEEL SHOE

## TECHNICAL DATA SHEET

<b>Material</b>	Poly Urethane Foam / Poly Iso Cyanurate Foam
<b>Density ( kg/m3)</b>	150 - 210 kg/m3 ( ASTM D792)
<b>Constant working temperature</b>	-180°C to 150°C
<b>Thermal Conductivity</b>	0.029 W/mK at 24°C ( ISO 8302 1991)
<b>Compressive Strength Mpa</b>	0.9MPa to 6.15 MPa ( ASTM 1621)
<b>Water absorption</b>	<10% weight ( ASTM D1056)
<b>Fire performance</b>	PU Foam : Standard class B2
<b>Enviromental friendly material free CFC, HCFC</b>	Good

Code	Example
PU - aD x bT - L	PU - 15A x 50T - 50
ULAR Dna x bT	ULAR Dn15A x 50T

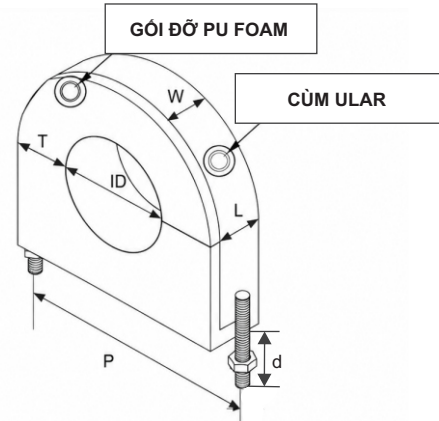

**T: Độ dày cách nhiệt**  
Insulation thickness  
**L: Bản rộng của gổ**  
Lenght of PUR  
**W: Bản rộng Ula**  
Wide of Uband  
**t: Độ dày lá thép Ula**  
Steel thickness

**P: Khoảng cách khoan ty**  
Distance to Drill threaded hole  
**d: Đường kính ty Ula**  
Inner diameter of Ula  
**DN: Đường kính danh nghĩa ống thép**  
Nominal diameter of steel pipe  
**ID: Đường kính trong của gổ**  
Inner diameter of the PUR  
**La: Chiều dài cùm Ula**

## BẢNG TIÊU CHUẨN KÍCH THƯỚC GÓI ĐỠ PU VÀ CÙM ULAR PRODETECH SẢN XUẤT

Ống Thép			Độ dày tiêu chuẩn PU																			
			50					40					32					25				
DN Đường kính ống thép (mm)	ID Đường (mm)	L (mm)	P (mm)	La Chiều dài Ular (mm)	t (mm)	d (mm)	w (mm)	P (mm)	La (mm)	t (mm)	d (mm)	w (mm)	P (mm)	La (mm)	t (mm)	d (mm)	w (mm)	P (mm)	La (mm)	t (mm)	Bulong (mm)	w (mm)
15A	22	30	134	284	2	8	30	114	232	2	8	30	98	191	2	8	30	84	155	2	8	30
20A	28	30	140	299	2	8	30	120	248	2	8	30	104	206	2	8	30	90	170	2	8	30
25A	35	30	147	317	2	8	30	127	266	2	8	30	111	224	2	8	30	97	188	2	8	30
32A	42	30	154	335	2	8	30	134	284	2	8	30	118	242	2	8	30	104	206	2	8	30
40A	48	30	160	350	2	8	30	140	299	2	8	30	124	258	2	8	30	110	222	2	8	30
50A	60	30	172	381	2	8	30	152	330	2	8	30	136	289	2	8	30	122	253	2	8	30
65A	76	30	188	422	2	8	30	168	371	2	8	30	152	330	2	8	30	138	294	2	8	30
80A	89	40	201	456	2	8	30	181	404	2	8	30	165	363	2	8	30	151	327	2	8	30
100A	114	40	228	500	2	10	30	208	449	2	10	30	192	407	2	10	30					
125A	140	40	254	567	2	10	30	234	515	2	10	30	218	474	2	10	30					
150A	168	50	282	639	2	10	30	262	587	2	10	30	246	546	2	10	30					
200A	219	50	335	770	2	12	30	315	718	2	12	30										
250A	273	50	389	909	2	12	30	369	857	2	12	30										
300A	323	50	439	1037	2	12	30	419	986	2	12	30										
350A	355	50	475	1119	3	14	30															
350A	377	50	497	1176	3	14	30															
400A	406	50	526	1257	3	14	30															
400A	419	50	539	1284	3	14	30															
400A	429	50	549	1310	3	14	30															
450A	457	80	577	1381	3	14	50															
450A	477	80	597	1433	3	14	50															
500A	509	80	629	1515	3	14	50															
500A	529	80	649	1567	3	14	50															
550A	559	80	679	1644	3	14	50															
600A	610	100	730	1775	3	14	50															
600A	630	100	750	1826	3	14	50															
650A	660	100	780	1903	3	14	50															
700A	711	100	833	2034	3	16	50															
700A	720	101	842	2057	3	16	50															
800A	813	150	935	2296	3	16	50															
800A	822	150	944	2320	3	16	50															

### 3. Features

- Good insulation: withstand temperatures from -400C to 1900C.
- Loading capacity up to 2.1 Mpa. The low water absorption, surface contact is coated waterproof, durable use.
- Lightweight: given the structure of the air bubbles, hold the foam cells for easy transportation and installation. Especially with PU Foam bearing no physical harm when installed and used, good cohesion.



- Remove heat bridges easily.
- Thermal conductivity coefficient is very low.
  - Excellent compression force.
  - There is glue available, creating tightness.
  - Synchronize with Uband / Ular / Ubold.
- Fire spread, self extinguishing, do not burn dripping

- PU Foam is spreads fire, self extinguishing
- There are rubber foam lining on the inner surface which tighten and absorbs vibration of operating pipeline.
- The inside surface has a built-in adhesive, convenient for installation.
- Smooth side, easy to connect with most insulation methods



\*\*\*

**PU Foam Prodetech products has rubber foam lining on the inner surface which tighten (steel pipes have tolerances) and absorbs vibration of operating pipeline. The outer surface is hard, smooth and shiny that to prevent moisture after installation. Fire spread, self-extinguishing, not dripping to meet the requirements of fire protection standards of construction works.**



**Ular** : Designed to Insulation pipe support PUR. The steel foil section is weled with the thyrod which not rust. The width of Ular increases the surface area exposed to the PUR's surface making the PUR firmly fixed.

1. Material: Cacbon Steel Ct3
2. Wel Standard: JIS Z3201
3. Finish: Electro-Galvanized, Hot dip-Galvanized.



## II. POLY- ISOCYANURATE FOAM ( PIR FOAM)

- ▲ Pir pipe foam ( Polyisocyanurate pipe foam) insulation is new professional cryogenic insulation material with high technology using so much in oil and petro factory manufacturer. With quality manager system ISO 9001:2008 and 5S standards of production. We are committed supply to market PIR pipe foam insulation with high quality and good price for use.
- ▲ PIR better than common polyurethane foam both in physical properties and fireproof performance, especially on cold insulation effects and fire retarding performance. PIR can be used in adiabatic demand of pipelines and equipment within  $-196\text{ }^{\circ}\text{C} \sim +150\text{ }^{\circ}\text{C}$  it also provides the best efficient and stable cold insulation effects for Liquefied Nitrogen ( LN  $-196\text{ }^{\circ}\text{C}$ ), Liquefied Natural Gas ( LNG,  $-162\text{ }^{\circ}\text{C}$ ), Liquefied Ethylene (LEG,  $-104\text{ }^{\circ}\text{C}$ ) PIR pipe foam insulation which our supply is using origin material foam famous company from American, Japan, Korean, Thailand, Singapore..
- ▲ The study evaluated the degree to which toxic product were released looking
- ▲ Mas Temperature Resistance to broken of aluminum films up to  $450\text{ }^{\circ}\text{C}$

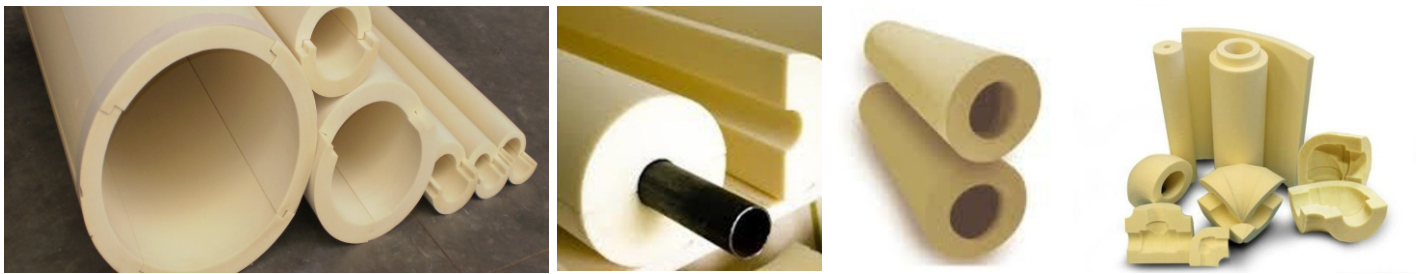

### Technical data product:

Discription	Unit	Standard Test Method	Result	Remark
Resistance to Fire		Euro class BS2D0, DIN 4102	Class B2	
Molded Density	Kg/m3		50 kg/m3	
Closed cells content	%	ASTM D1622	>92KG/M3	
Initial thermalconductivity @23°C	W/mK		0.024	
Dimensional strenght ( perpendicular to the main plan of the panel)	kPa		170	
Dimensional stability ( linear changes) 24hours at $-25\text{ }^{\circ}\text{C}$	%		Max 1%	
Dimensional stability ( linear changes) 24hours at $70\text{ }^{\circ}\text{C}$	%		Max 1%	
The proposed service temp			$-196\text{ }^{\circ}\text{C} \rightarrow 150\text{ }^{\circ}\text{C}$	

## IV. RESTING SHOE

**Material :** - Pre galvanized steel (PG)

- Hot Dip galvanized (HDG)

- Powder (PC)

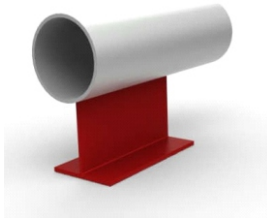

**Code : RS1**

Pipe	L	B	H	C	T1	T2
2.1/2"	300	75	150	200	6	9
3"	300	150		200	9	9
4"	300	150		200	9	9
5"	300	150		200	9	9
6"	300	150		200	9	9

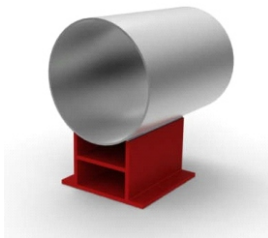

**Code : RS2**

Pipe	L	B	B1	H	G	T1	T2
8"	300	150	30	170	40	12	12
10"	300	150	30	165	40	12	12
12"	300	200	50	175	40	12	12
14"	300	200	50	175	40	12	12
16"	300	200	50		40	12	12
18"	300	200	50		40	12	12
20"	300	250	60		40	12	12

## V. GUIDE SHOE

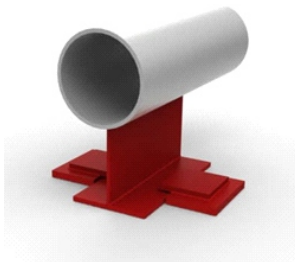

**Code : GS1**

Pipe	L	B	H	C	T1	T2
2.1/2"	300	75	150	200	6	9
3"	300	150		200	9	9
4"	300	150		200	9	9
5"	300	150		200	9	9
6"	300	150		200	9	9

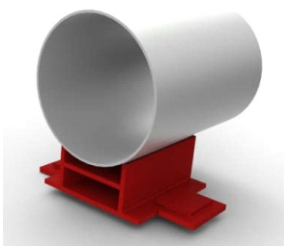

**Code : GS2**

Pipe	L	B	B1	H	G	T1	T2
8"	300	150	30	170	40	12	12
10"	300	150	30	165	40	12	12
12"	300	200	50	175	40	12	12
14"	300	200	50	175	40	12	12
16"	300	200	50		40	12	12
18"	300	200	50		40	12	12
20"	300	250	60		40	12	12

Other size can be produce upon request with difference specification.

### III. CHILLER SHOE

Material : - Pre galvanized steel (PG) - Hot Dip galvanized (HDG) - Powder (PC)

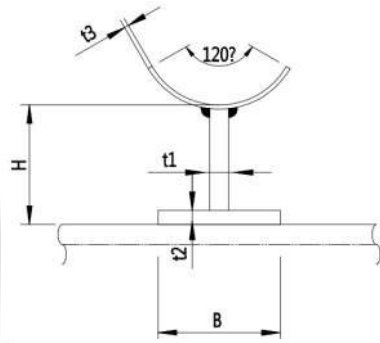
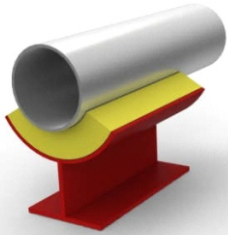

Pipe	L	B	H	C	T1	T2	T3
2.1/2"	300	75	100	20	6	9	6
3"	300	150		20	9	9	6
4"	300	150		20	9	9	6
5"	300	150		20	9	9	6
6"	300	150		20	9	9	6

Code : CS1

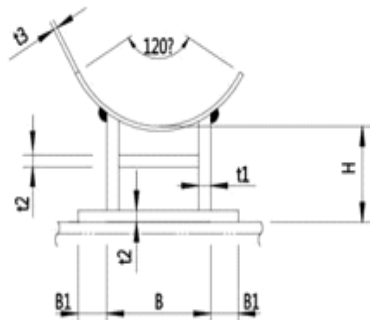
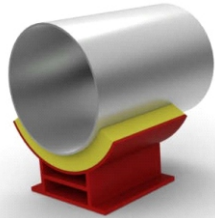

Pipe	L	B	B1	H	G	T1	T2	T3
8"	300	150	30	100	400	12	12	6
10"	300	150	30	100	400	12	12	6
12"	300	200	50	100	400	12	12	9
14"	300	200	50	100	400	12	12	9
16"	300	200	50	100	400	12	12	9
18"	300	200	50	100	400	12	12	9
20"	300	250	60	100	500	12	12	9
22"	300	250	60	100	500	12	12	9

Code : CS2

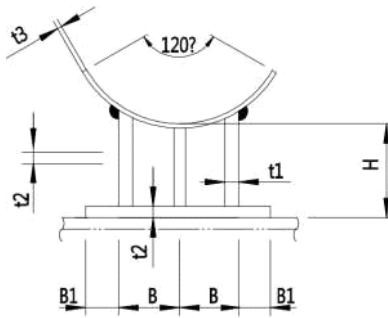
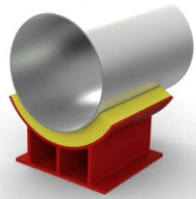

Pipe	L	B	B1	H	G	T1	T2	T3
24"	350	125	60	100	500	12	12	9
26"	350	125	60	100	500	12	12	9
28"	350	175	60	100	500	12	12	9

Code : CS3

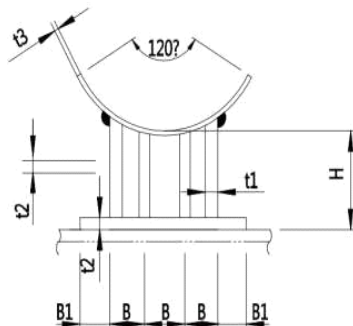
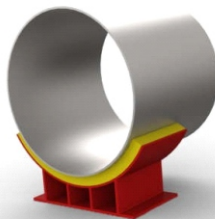

Pipe	L	B	B1	H	G	T1	T2	T3
30"	350	150	80	100	600	12	12	9
32"	350	150	80	100	600	12	12	12

Code : CS4

Other size can be produce upon request with difference specification.

## VI. EVA FOAM PIPE SUPPORT

EVA rubber pillow is a pipe support material made from polyvinyl alcohol (EVA) material, which has excellent physical and chemical properties, can effectively protect pipes from the impact of the external environment and Extends pipe life.

At the same time, the EVA rubber plastic pipe holder also has good shock absorption, vibration absorption and sound insulation effects, which can effectively reduce noise and vibration during pipeline operation, while improving the durability, safety and stability of pipelines.



**EVA Support  
code : EVA - aDxbT-L**

No	Specifications	Unit	Standard Test	Parameter
1	Color	Table color	ISO 105-A02:1993	Black
2	Surface			Smooth
3	Thickness	mm		3~5mm
4	Density	g/cm <sup>3</sup>	ASTM D1622	1,35g/cm <sup>3</sup> - 2.0g/cm <sup>3</sup>
5	Hardness	HB	TCVN 1595-1; 2007	7~20HB
6	Pressure	Mpa	ASTM D1621	0.13Mpa - 0.5Mpa
7	Tensile Strength	Mpa	ASTM D1622	0.2Mpa - 0.3Mpa
8	Elongation	%	TCVN 4509:2006	200%-300%
9	Temperature Service		GB/T8871	-30 ~ +80

## VII. WOODEN PIPE SUPPORT

Wooden support are a product constructed from wood to create stability and support loads. They are used to reduce vibrations and withstand loads in construction and industrial applications.

Our company's wooden pipe racks are all made of high-quality wood, sturdy, not easily deformed, never use reprocessed old wood, no preservatives and environmentally friendly.



**Wooden Support  
code : PUW - aDxbT-L**

Item	Specification	Standard
Materials	Wooden	Standard
Density	800±100 kg/m <sup>3</sup>	ASTM D1622
Thermal conductivity	0.032 W/mK	ASTM C518
Working temperature	-50 °C -> 150 °C	ASTM 1621
Compressive Strength	10.5Mpa	ASTM D1621
Environmental friendly material, free CFC	Good	ASTM D1056

## VI. PE PIPE SUPPORT

Made primarily from PE as the base material, with added flame retardants and modifiers, it offers excellent thermal insulation, water resistance, and acid-base resistance.

This material is hard, has a high load-bearing capacity, and features shockproof, heat-insulating, flame-retardant, and thermal insulation properties.

It is combined with galvanized clamp rings that have undergone anti-rust treatment, making it easy to install, cost-effective, and aesthetically pleasing.

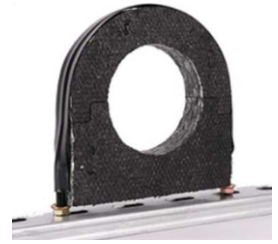

**PE Support  
code : PE - aDxbT-L**



**P-TYPE**

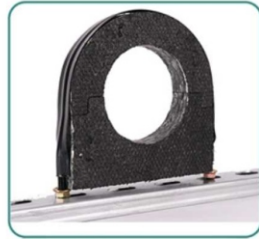

**U-TYPE**

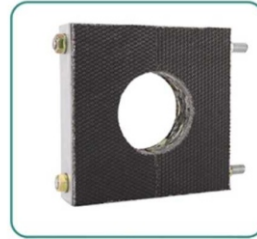

**SQUARE**



**CIRCLE**

### TECHNICAL SPECIFICATIONS

MODEL	SPECIFICATIONS		BEARING (kg)	SPAN (m)	PI+G2:G25PE HOLDER INNER DIAMETER EXPANSION VALUE	DRILLING DISTANCE (mm)	STEEL STRIP RING	
	PIPE DIAMETER	BEARING WIDTH * INSULATION THICKNESS (±2mm)					SPECIFICATIONS	SCREWS AND NUTS
COPPER TUBE	φ9	25*25	83,8	4	±1	67	0.8*20mm	M8
	φ12	25*25	83,8	4	±1	70		
	φ16	25*25	83,8	4	±1	74		
	φ19	25*25	8,3	4	±1	77		
DN15	φ22	25*25	83,8	4	±1	80		
	φ25	25*25				83		
DN20	φ28	25*25	83,8	4	±1.2	86		
DN25	φ34	25*25	101,8	4	±1.2	92		
	φ38	25*25			±1.2	96		
DN32	φ40	25*25	106,9	4	±1.2	99		
	φ43	25*25			±1.2	101		
DN40	φ45	25*25	179,6	4	±1.5	103		
	φ48	25*25			±1.5	106		
	φ50	25*25			±1.5	109		
	φ57	25*25			±1.5	115		
DN50	φ60	25*25	224,5	4	±1.5	118		
	φ63	25*25			±1.5	121		
	φ67	25*25			±1.5	125		
DN65	φ76	25*25	341,2	4	±1.5	134		
DN80	φ89	30*30	399,6	4	±1.5	157		
DN100	φ102	30*30	483,2	4	±1.5	170		
	φ108	30*30			±1.5	176		
	φ110	30*30	511,8	4	±1.5	178		
	φ114	30*30			±1.5	182		
DN120	φ133	40*40	796,2	5	±2	223	1.0*32mm	M10
DN125	φ140	40*40	838,1	5	±2	230		
DN140	φ159	40*40	954,8	5	±2	249		
DN150	φ165	40*40	987,7	5	±2	255		
DN200	φ219	50*50	1638,8	4	±2	331		
DN250	φ273	50*50	2042,9	4	±2	385	1.5*40mm	M12
DN300	φ325	50*50	2432,0	4	±2	437		
DN350	φ377	50*50	2821,1	4	±2	489		
DN400	φ426	50*50	3187,8	4	±2	538		
DN450	φ478	50*50	3479,6	4	±2	590		
DN500	φ530	50*50	3966,0	4	±2	644		
DN600	φ630	50*50	5654,9	4	±2	744		
DN700	φ720	50*50	4714,3	4	±2	834		

Other size can be produce upon request with difference specification.

## VIII. ACCESSORIES FOR PIPE SUPPORT

### 1. Ular

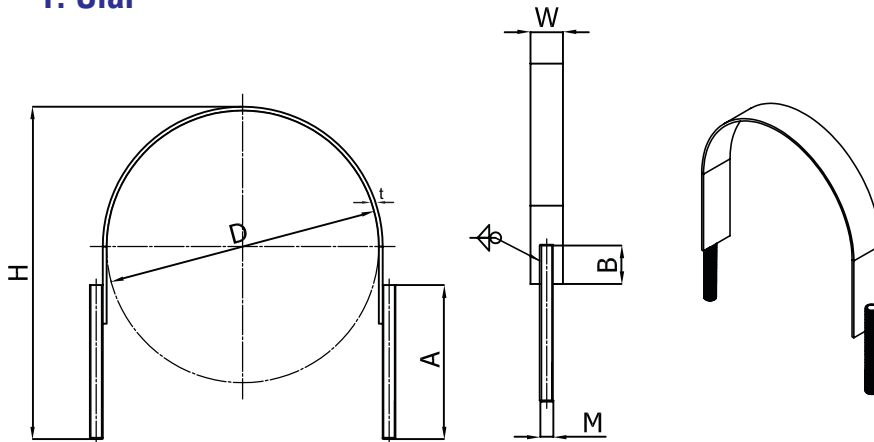

**ULAR**  
code : ULAR Dna x bT

#### Products Description:

##### Material:

- Steel,
- Aluminum,
- Stainless steel

##### Finishing Surface:

- Powder coating
- Alkyd paint
- Hot deep Galvanized
- Zinc coating

##### Thickness:

- 1,5mm; 2,0mm; 2,5mm; 3,0mm

#### Technical data product:

Code	DN	D (mm)	H (mm)	A (mm)	B (mm)	M (Ty Ren)	W (mm)
Ular 15A	15	21.7	47	40	10	M8	25; 30
Ular 20A	20	27.2	53	40	10	M8	25; 30
Ular 25A	25	34.0	60.0	40	10	M8	25; 30
Ular 32A	32	42.7	68	40	10	M8	25; 30
Ular 40A	40	48.6	75	40	10	M8;M10	25; 30; 40
Ular 50A	50	60.5	96	50	10	M8;M10	25; 30; 40
Ular 65A	65	76.3	120	60	12	M8;M10	25; 30; 40
Ular 80A	80	89.1	134	60	12	M8;M10	25; 30; 40
Ular 100A	100	114.3	154	60	15	M8;M10	25; 30; 40
Ular 125A	125	139.8	185	70	20	M8;M10	25; 30; 40
Ular 150A	150	165.2	213	70	20	M8;M10	25; 30; 40
Ular 200A	200	216.3	282	90	20	M10;M12	25; 30; 40; 50
Ular 250A	250	267.4	336	90	20	M10;M12	25; 30; 40; 50
Ular 300A	323	325	375	90	20	M12	40; 50
Ular 350A	357	375	435	90	20	M12	40; 50
Ular 400A	409	430	485	90	20	M12	40; 50

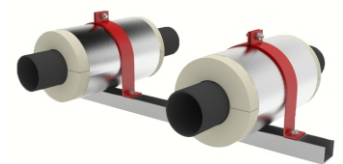

Other size can be produce upon request with difference specification.

## VIII. ACCESSORIES FOR PIPE SUPPORT

### 7. INSULATION PIPE CLAMP BRACKET

#### - APPLICATION

Used for galvanized pipes, seamless pipes, stainless steel, PVC, PPR pipes, and photovoltaic clips

#### - ADVANTAGE

Sturdy and wear-resistant, corrosion and rust-resistant, high hardness.

#### - MATERIALS

Available in materials such as  
Hot-dip galvanized  
Electroplated galvanized  
Stainless steel  
Inox

Bracket materials:  
PU FOAM  
PE  
EVA

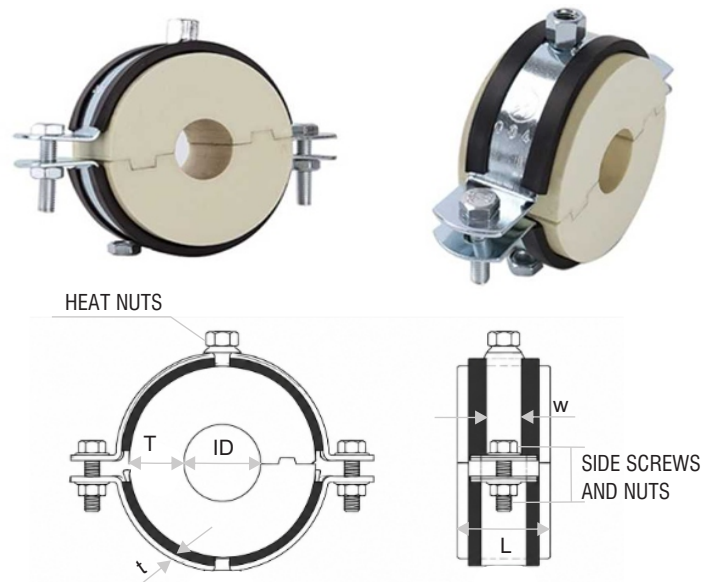

Code : IPC - aD x bt - w  
Example : IPC - Dn15 x 2.0t -32

#### TECHNICAL SPECIFICATIONS

MODEL	SPECIFICATIONS (mm)		INSULATION DENSITY	STEEL STRIP RING			
	PIPE DIAMETER	BEARING WIDTH * INSULATION THICKNESS (±2mm)		WIDTH * THICKNESS (mm)	SIDE SCREWS AND NUTS	HEAD NUTS	
Copper tube	φ9	40*25	250/+/- 50 kg/m3	32*2.0	M8		
	φ12	40*25	250/+/- 50 kg/m3				
	φ16	40*25	250/+/- 50 kg/m3				
	φ19	40*25	250/+/- 50 kg/m3				
DN15	φ22	40*25	250/+/- 50 kg/m3				
DN20	φ28	40*25	250/+/- 50 kg/m3				
DN25	φ34	40*25	250/+/- 50 kg/m3				
	φ38	40*25	250/+/- 50 kg/m3				
DN32	φ40	40*25	250/+/- 50 kg/m3				
	φ43	40*25	250/+/- 50 kg/m3				
DN40	φ45	40*25	250/+/- 50 kg/m3				
	φ48	40*25	250/+/- 50 kg/m3				
	φ50	40*25	250/+/- 50 kg/m3				
DN50	φ60	40*25	250/+/- 50 kg/m3				
	φ63	40*25	250/+/- 50 kg/m3				
	φ67	40*25	250/+/- 50 kg/m3				
DN65	φ76	40*30	250/+/- 50 kg/m3		32*2.5		M10
DN80	φ89	40*30	250/+/- 50 kg/m3				
DN100	φ102	40*30	250/+/- 50 kg/m3				
	φ108	40*30	250/+/- 50 kg/m3				
	φ110	40*30	250/+/- 50 kg/m3				
	φ114	40*30	250/+/- 50 kg/m3				
DN120	φ133	40*40	250/+/- 50 kg/m3				
DN125	φ140	40*40	250/+/- 50 kg/m3				
DN140	φ159	40*40	250/+/- 50 kg/m3				
DN150	φ165	40*40	250/+/- 50 kg/m3				
DN200	φ219	50*50	250/+/- 50 kg/m3	32*3.0			
DN250	φ273	50*50	250/+/- 50 kg/m3				
DN300	φ325	50*50	250/+/- 50 kg/m3				
DN350	φ377	50*50	250/+/- 50 kg/m3				
DN400	φ426	50*50	250/+/- 50 kg/m3				
DN450	φ478	50*50	250/+/- 50 kg/m3				
DN500	φ530	50*50	250/+/- 50 kg/m3				
DN600	φ630	50*50	250/+/- 50 kg/m3				
DN700	φ720	50*50	250/+/- 50 kg/m3	32*4.0			

Other size can be produce upon request with difference specification.

## VIII. ACCESSORIES FOR PIPE SUPPORT

### 6. HEAVY - DUTY PIPE CLAMP BRACKET

#### CHARACTERISTIC

Two locking nuts for easy adjustment according to pipe size and specifications. CO2 welded bolt joints enhance strength. Bolts feature a plastic outer coating, anti-loosening washers, and EPDM black soundproof and insulation liners, offering aging resistance. Tested for noise reduction (DIN4109) and fire resistance. Suitable for fire protection pipes, HVAC water pipes, sprinkler pipes, hot water pipes, and water supply/drainage pipes below DN500.



**Code : HPC - Dna**  
**Example : HPC - Dn15**

#### TECHNICAL SPECIFICATIONS

SPECIFICATIONS	LIMIT FOR THE USE (mm)	DIAMETER DN	WIDTH x THICKNESS (mm)	SCREWS AND NUTS
HPC-15Ax2.5t-30	15-19	15	30 x 2.5	M8/M10
HPC-20Ax2.5t-30	20-25	20	30 x 2.5	M8/M10
HPC-25Ax2.5t-30	32-36	25	30 x 2.5	M8/M10
HPC-32Ax2.5t-30	38-43	32	30 x 2.5	M8/M10
HPC-40Ax2.5t-30	47-51	40	30 x 2.5	M8/M10
HPC-50Ax2.5t-30	53-58	50	30 x 2.5	M8/M10
HPC-65Ax3.0t-30	75-80	65	30 x 3.0	M8/M10
HPC-80Ax3.0t-30	87-92	80	30 x 3.0	M8/M10
HPC-100Ax3.0t-30	107-112	100	30 x 3.0	M8/M10
HPC-125Ax3.0t-30	132-137	125	30 x 3.0	M12
HPC-150Ax4.0t-38	159-166	150	38 x 4.0	M16
HPC-200Ax4.0t-38	212-225	200	38 x 4.0	M16
HPC-250Ax5.0t-48	266-275	250	48 x 5.0	M16
HPC-300Ax5.0t-48	320-329	300	48 x 5.0	M16

*Other size can be produce upon request with difference specification.*

## VIII. ACCESSORIES FOR PIPE SUPPORT

### 8. PIPE CLAMP BRACKET

#### - APPLICATION

Used for the fixation of light pipes with a diameter < 100mm in engineering projects.

#### - ADVANTAGE

The modular design of the pipeline makes installation, inspection and maintenance more convenient.

#### - MATERIALS

Available in materials such as

Hot-dip galvanized

Electroplated galvanized

Stainless steel



Code : PC - Dna  
Example : PC - Dn15

#### TECHNICAL SPECIFICATIONS

SPECIFICATIONS	DIAMETER (mm)	WIDTH * THICKNESS (mm)	SIDES SCREWS AND NUTS	HEAD NUTS
DN15	19-22	32×2.0	M8	M10/M12
DN20	26-28	32×2.0	M8	M10/M12
DN25	32-36	32×2.0	M8	M10/M12
DN32	38-43	32×2.0	M8	M10/M12
DN40	48-51	32×2.0	M8	M10/M12
DN50	50-63	32×2.0	M8	M10/M12
DN65	65-76	32×2.0	M10	M10/M12
DN80	89-93	32×2.5	M10	M10/M12
DN100	108-114	32×2.5	M10	M10/M12
DN125	133-140	32×2.5	M10	M10/M12
DN150	159-165	32×2.5	M10	M10/M12
DN200	219	32×3.0	M10	M10/M12
DN250	273	32×3.0	M10	M10/M12
DN300	325	32×3.0	M10	M10/M12
DN350	377	32×3.0	M10	M10/M12
DN400	426	32×4.0	M10	M10/M12
DN450	478	32×4.0	M10	M10/M12
DN500	530	32×4.0	M10	M10/M12

*Other size can be produce upon request with difference specification.*

## VIII. ACCESSORIES FOR PIPE SUPPORT

### 2. U - Bolts

Detail	Specification
Quality	Hard, strong
Material	Carbon, steel
Origin	Prodotech / Made in VN
Surface	Electrolytic galvanized according to ASTM B633 standard
Color	White, red..

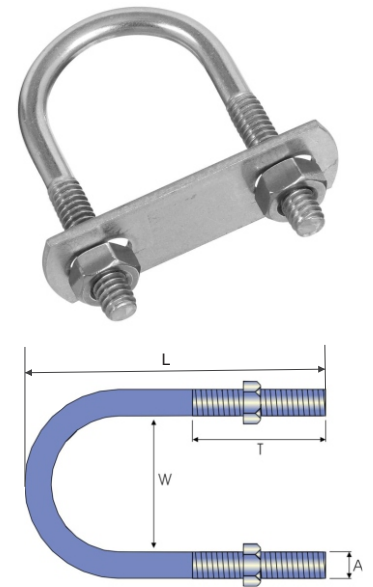

**Code : UB - Dna**  
**Example : UB - Dn15**

### TECHNICAL SPECCIFICATIONS

CODE	DIAMETER (mm)	LENGTH (mm)	WEIGHT (g)	NUTS
DN15	4,9	130	19	M6
DN20	4,9	130	20,7	M6
DN25	4,9	142	22,8	M6
DN32	6,5	195	51,6	M8
DN40	6,5	220	59,4	M8
DN50	6,5	245	68,7	M8
DN65	8,2	282	82,5	M10
DN80	8,2	330	136,1	M10
DN100	8,2	370	152,3	M10
DN125	8,2	450	208	M10
DN150	8,2	555	252	M10
DN200	10,2	700	462,4	M12
DN250	10,4	865	595	M12
DN300	10,4	990	680	M12
DN350	10,4	1136	780	M12
DN400	10,4	1285	880	M12
DN450	10,4	1420	975	M12
DN500	12,4	1500	1430	M14
DN600	12,4	1740	1650	M14

*Other size can be produce upon request with difference specification.*

## VIII. ACCESSORIES FOR PIPE SUPPORT

### 3. OMEGA - SHAPE

Detail	Specification
Quality	Hard, strong
Material	Carbon, steel
Origin	Prodotech / Made in VN
Surface	Electrolytic galvanized according to ASTM B633 standard
Color	White, red..

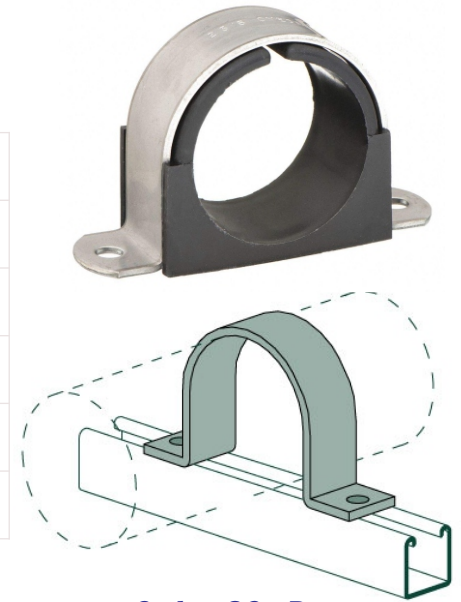

**Code : OG - Dna**  
**Example : OG - Dn15**

#### TECHNICAL SPECIFICATIONS

Part No	Size	D	A	B	Bolt size	Strip size
		mm	mm	mm		mm
15A	1.2"	22	76	51	M8	25x2
20A	3/4"	28	82	57	M8	25x2
25A	1"	35	89	64	M8	25x2
32A	1-1/4"	42	96	71	M8	25x2
40A	1-1/2"	48	102	77	M8	25x2
50A	2"	54	108	83	M8	25x2
65A	2-1/2"	60	114	89	M8	25x2
80A	3"	67	121	96	M8	25x2
100A	4"	75	145	113	M8	25x2
125A	5"	82	152	128	M8	25x2
150A	6"	90	160	138	M8	25x2
200A	8"	100	160	138	M8	25x2
250A	10"	108	178	153	M8	25x2
300A	12"	115	185	164	M8	25x2.5

## VIII. ACCESSORIES FOR PIPE SUPPORT

### 4. P - TYPE

#### - APPLICATION

Used for fixing fire protection pipes and C-shaped steel pipes.

#### - ADVANTAGE

The rubber strip offers excellent insulation performance, corrosion resistance, and wear resistance, making installation convenient.

#### - MATERIALS

Available in materials such as  
Hot-dip galvanized  
Electroplated galvanized  
Stainless steel



P - TYPE  
PIPE CLAMP



PIPE CLAMP  
WITH RUBER STRIP



PIPE CLAMP  
WITH RUBER LINE

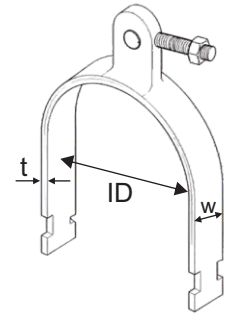

Code : PTYPE - Dna  
Example : PTYPE -Dn15

### TECHNICAL SPECIFICATIONS

SPECIFICATIONS	DIAMETER (mm)	WIDTH * THICKNESS (mm)	SCREWS AND NUTS
DN15	22	32×2.0	M8
DN20	28	32×2.0	M8
DN25	34	32×2.0	M8
DN32	43	32×2.0	M8
DN40	48	32×2.0	M10
DN50	50	32×2.0	M10
DN65	76	32×2.0	M10
DN80	89	32×2.5	M10
DN100	114	32×2.5	M10
DN125	140	32×2.5	M10
DN150	165	32×2.5	M10
DN200	219	32×3.0	M10
DN250	273	32×3.0	M10
DN300	325	32×3.0	M10
DN350	377	32×3.0	M10
DN400	426	32×4.0	M10
DN450	478	32×4.0	M10
DN500	530	32×4.0	M10
DN600	630	32×4.0	M10
DN700	720	32×4.0	M10

Other size can be produce upon request with difference specification.

## VIII. ACCESSORIES FOR PIPE SUPPORT

### 5. 0 - SHAPE

#### - APPLICATION

Used for galvanized pipes, seamless pipes, stainless steel, PVC, PPR pipes, and photovoltaic clips

#### - ADVANTAGE

Sturdy and wear-resistant, corrosion and rust-resistant, high hardness.

#### - MATERIALS

Available in materials such as  
Hot-dip galvanized  
Electroplated galvanized  
Stainless steel



**Code : 0TYPE - Dna**  
**Example : 0TYPE -Dn15**

#### TECHNICAL SPECCIFICATIONS

DIAMETER	WIDTH * THICKNESS (mm)	HEAD NUTS
DN15	20*1.0	M8/M10
DN20		
DN25		
DN32		
DN40		
DN50		
DN65		
DN80		
DN100		
DN125		
DN150		
DN200		
DN250		
DN300		

*Other size can be produce upon request with difference specification.*

## VIII. ACCESSORIES FOR PIPE SUPPORT

### 9. PRODETECH STEEL PIPE CLAMP RING

According to different construction requirements, our company can provide various U-type, O-type, P-type (for C-shaped steel) and other series of hardware pipe clamps made from different materials (stainless steel, white zinc, black zinc, colored zinc, etc.). We can also customize the required clamps and fasteners according to customer-provided drawings or samples.



Electrophoresis U Clamp



Color-Plated Zinc U Clamp



Galvanized U Clamp



Stainless Steel U Clamp



O-shape Clamp



O-shape Clamp



Omega-shape Clamp



P-type Pipe Clamp

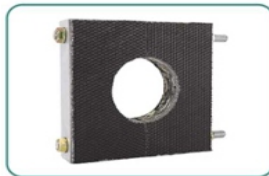

Square-shape Clamp



Omega-shape Clamp  
with Rubber

### 10. FIXED / SLIDE HEAVY-DUTY PIPE SUPPORT

Large steam insulation pipe supports, steel fixed pipe support, sliding pipe supports, pipeline fixing supports, guide-type pipe support, etc.

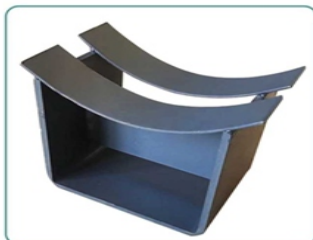
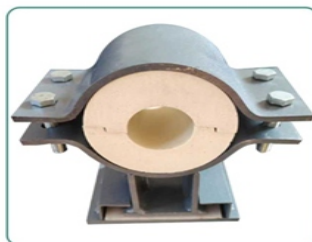

### 15. UNISTRUT & FITTING

#### Unistrut



#### Cantilever Arm

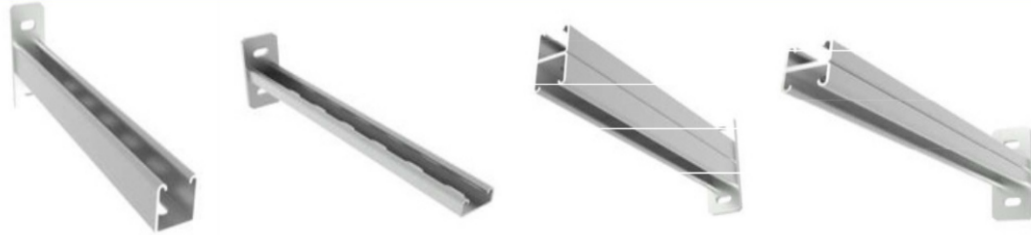

#### Flat Plate Fitting



#### Angular Fitting



## VIII. ACCESSORIES FOR PIPE SUPPORT

### 16. VIBRATION RUBBER HARNESS FLAT SHEET



#### INTRODUCE :

ATATA vibration rubber harness flat sheet is product with high density, smooth surface, high hardness, good strength compared to other types of rubber :

Rubber special classification :

- Thickness : Rubber plate thickness : 5mm , 10mm, 13mm, 15mm, 20mm, 25mm.
- Width : 400mm - 60mm
- Mechanical properties : Rubber bearing, rubber anti - vibration , shock..
- Mateial : NBR ( Nitrile Butadien Rubber).

#### TECHNICAL SPECIFICATIONS

No	Specification	Unit	Standard Test	Parameter
1	Color	Table color	ISO 105-A02:1993	Black
2	Surface			smooth
3	Thickness	mm		30mm~25mm
4	Density	g/cm3	ASTM D1622	1.35g/cm3 - 2.0g/cm3
5	Hardness	HB	TCVN 1595-1:2007	7~20 HB
6	Pressure	Mpa	ASTM D1621	1.3Mpa ~ 6.0Mpa
7	Tensile strength	Mpa	ASTM D1622	2 Mpa ~ 3Mpa
8	Elongation	%	TCVN 4509:2006	200% -300%
9	Temperature Service	C	GB/T8871	-30C ~ +80C

### 17. RUBBER PADS





# E. Test Report

## 2. Test Report PIR Foam



**BỘ XÂY DỰNG**  
**VIỆN KHOA HỌC CÔNG NGHỆ XÂY DỰNG**  
Ministry of Construction  
Viet Nam Institute for Building Science and Technology (IBST)  
Trung tâm Tư vấn Xây dựng Công nghiệp & Hạ tầng  
Address: 81 Trần Công-Nghĩa tam - Cầu Giấy - Hà Nội. Tel: 84.4.37542796 Fax: 84.4.38361197

HD số 69 / 2015 TVCNHT

**PHIẾU KẾT QUẢ/ TEST REPORT**

Công ty gửi mẫu/ Client: CÔNG TY TNHH PHÁT TRIỂN CÔNG NGHỆ TIN HỌC VÀ THƯƠNG MẠI HÒA BÌNH  
Địa chỉ : Cúm công nghiệp Yên Sơn, xã Yên Sơn, Quốc Oai, Hà Nội  
Điện thoại : 04.33940189 Fax: 04.33678853  
Mẫu thử/ Test sample: Vật liệu PIR Foam (Polyisocyanurate Pipe Foam)  
Chiều dày mẫu/ sample thickness (mm): 25  
Mẫu được bảo quản trước khi thử ở điều kiện nhiệt độ (°C): 24 và độ ẩm (%): 60  
Conditioned before testing to constant mass at (°C): 24 °C and relative humidity (%): 60  
Phương pháp thử/Test method: Phương pháp tấm nhiệt theo ISO 8302:1991  
Guarded hot plate method  
Nhiệt độ trong phòng thử (°C): 24 Độ ẩm tương đối (%): 60  
Temperature in test rooms Relative air humidity in test rooms  
Ngày thử nghiệm/ Date of Test: 29 / 10 / 2015  
Thiết bị/ Test Equipment: Plate Thermal Conductivity Tester.DRX-1-PB

Chỉ tiêu/Item	Đơn vị/Unit	Kết quả/ Result	Ghi chú
Hệ số dẫn nhiệt (λ)/ Thermal conductivity (λ)	W/m.K	0,024	

*Ghi chú/ Note: Kết quả chỉ có giá trị đối với mẫu thử do Công ty TNHH phát triển công nghệ tin học và Thương mại Hòa Bình cung cấp.  
The above result is valid for only test sample supplied by Công ty TNHH phát triển công nghệ tin học và Thương mại Hòa Bình to laboratory LAS-XD 04. The laboratory LAS-XD 04 therefore assumes no responsibility for the accuracy of information on brand name, origin of manufacture or any information supplied.*

Hà Nội, ngày 5 tháng 11 năm 2015

Người thực hiện/ Tested by: Phạm Đức Hạnh  
Phòng TN/ Laboratory LAS-XD 04  
Trưởng phòng/ Head: Nguyễn Sơn Lâm

Cơ quan thực hiện/ Trung tâm TVXD&CN & Hạ tầng Công nghiệp và Hạ tầng/ Industrial and Infrastructure Engineering  
Nguyễn Sơn Lâm

BM - ISO 97 (LAS-XD 04) - 02



**BỘ XÂY DỰNG**  
**VIỆN KHOA HỌC CÔNG NGHỆ XÂY DỰNG**  
Ministry of Construction  
Viet Nam Institute for Building Science and Technology (IBST)  
Trung tâm Tư vấn Xây dựng Công nghiệp & Hạ tầng  
Address: 81 Trần Công-Nghĩa tam - Cầu Giấy - Hà Nội. Tel: 84.4.37542796 Fax: 84.4.38361197

HD số 69 / 2015 TVCNHT

**PHỤ LỤC/ APPENDIX**  
Ảnh mẫu thử/ Photo of test sample

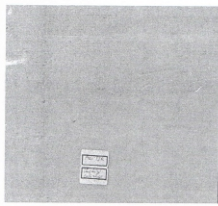
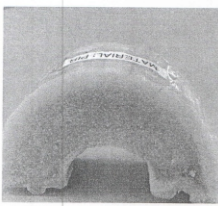
Ảnh: Mẫu PIR Foam (Polyisocyanurate Pipe Foam) (Photo: Test sample as received)



**VIỆN HÀN LÂM KHOA HỌC VÀ CÔNG NGHỆ VIỆT NAM**  
VIETNAM ACADEMY OF SCIENCE AND TECHNOLOGY  
**VIỆN KỸ THUẬT NHIỆT ĐỘ**  
Institute for Tropical Technology

Địa chỉ / Address: 18, Hoàng Quốc Việt, Cầu Giấy, Hà Nội  
Điện thoại / Tel.: (04) 38 361 322  
Fax: (04) 37 564 696

No.151028/TNK Hà Nội, ngày tháng năm 2015

### KẾT QUẢ THỬ NGHIỆM (TEST REPORT)

- Khách hàng / Customer: Công ty TNHH Phát triển Công nghệ Tin học và Thương mại Hòa Bình/ DETI CO.,LTD
- Vật liệu, sản phẩm thử nghiệm / Materials, products: Ống xếp cách nhiệt Polyisocyanurate (PIR)/Polyisocyanurate pipe foam (PIR)
- Nguồn gốc mẫu/Origin of sample: ATATA Thermal Break & Sound Proof
- Ngày nhận mẫu/Date of receiving: 28/10/2015
- Kết quả / Results:

STT	Loại thử nghiệm/ Types of test	Phương pháp thử nghiệm/ Test method	Kết quả/ Results
1	Cường độ chịu nén, kPa Compressive Strength, kPa	ASTM D1621	170
2	Phân tích nhiệt Thermal analysis	ASTM D4591	Phụ lục kèm theo
3	Khối lượng riêng, Kg/m <sup>3</sup> Molded density, Kg/m <sup>3</sup>	Khối lượng/Mass method	55

Thử nghiệm viên/ Technician: ThS. Phạm Thị Hà

Phụ trách Phòng Thử nghiệm/ Head of the Testing Laboratory: KS. Nguyễn Văn Tuấn

Viện Kỹ thuật nhiệt đới  
xác nhận chữ ký của ông Nguyễn Văn Tuấn  
Signature confirmation of Eg. Nguyễn Văn Tuấn  
by the Institute for Tropical Technology  
**VIỆN TRƯỞNG/ DIRECTOR**  
GS.TS. Thái Hoàng



Thiết bị thử nghiệm Hiệu chỉnh ngọn lửa mỗi trước thử nghiệm

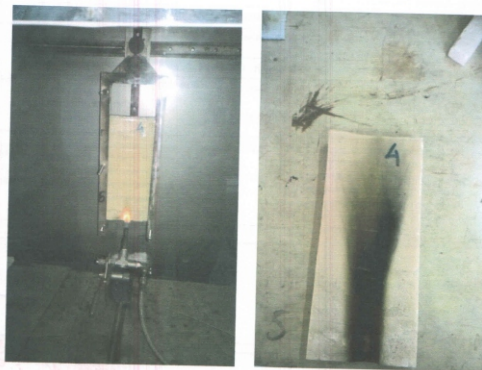

Thử nghiệm tính bất cháy Mẫu sau thử nghiệm bất cháy

1. Phiếu kết quả này chỉ có giá trị đối với mẫu thử do khách hàng đưa tới / This test results report is only valid for samples provided by customer.  
2. Không được trích sao một phần kết quả này nếu không được sự đồng ý của Viện Kỹ thuật nhiệt đới / Duplication of this report or parts thereof is only permitted by the Institute for Tropical Technology.  
3. Tên mẫu và tên khách hàng được ghi theo yêu cầu của khách hàng / Sample's name and customer's name are provided by customer.

## 3. Test Report Steel Shoe

**Quatest 1** TỔNG CỤC TIÊU CHUẨN ĐO LƯỜNG CHẤT LƯỢNG  
Directorate for Standards Metrology and Quality  
TRUNG TÂM KỸ THUẬT TIÊU CHUẨN ĐO LƯỜNG CHẤT LƯỢNG  
Quality Assurance and Testing Center 1

Trụ sở chính: 55 B Hoàng Quốc Việt,  
Cầu Giấy - Hà Nội  
Tel: (024) 38361399 - Fax: (024) 38361199  
Email: www.qltest1.com.vn  
Cơ sở 2: Khu CN Nam Thăng Long,  
Độc lập - Hà Nội  
Tel: (024) 32191022 - Fax: (024) 32191021

Số No.: 241/TKM/0293\_1 Trang/Pag.: 4/4

### KẾT QUẢ THỬ NGHIỆM

TEST RESULT

1. Tên mẫu thử/Sample: **GÓI ĐÓ THÉP STEEL SHOE**  
2. Khách hàng/Customer: **THÉP TÂM DÀY 6mm - NHÀ SẢN XUẤT: PRODETECH**  
3. Số lượng mẫu/Quantity: 01  
4. Tình trạng mẫu/Observation: Xem ảnh kèm theo  
5. Ngày nhận mẫu/Reception date: 19/02/2024  
6. Thời gian thử nghiệm/Time duration: 21/02/2024  
7. Ngày hoàn thành/Completion Date: 21/02/2024

TT Items	TÊN CHỈ TIÊU Specifications	P. PHÁP THỬ Test methods	M. QUY ĐỊNH Requirements	KẾT QUẢ Results	
1	• Giới hạn chảy Yield strength	MPa	JIS Z2241 : 2022	≥ 245	290
	• Độ bền kéo Tensile strength		400 - 510	428	
	• Độ giãn dài Elongation		≥ 17	28	



Hà Nội, ngày 22/02/2024  
P. TRƯỞNG PHÒNG THỬ NGHIỆM CƠ KHÍ - VLXD  
Head of Mechanical and Construction Material testing lab.

Nguyễn Văn Minh  
PHÓ GIÁM ĐỐC  
Nguyễn Ngọc Châm

1. Phiếu kết quả này chỉ có giá trị đối với mẫu thử do khách hàng đưa tới.  
This test result is valid only for samples taken by customer.  
2. Không được trích sao một phần kết quả này nếu không được sự đồng ý của trung tâm KỸ THUẬT 1.  
This test results shall not be reproduced except in full, without the written approval of QUATEST 1.  
3. Tên mẫu và tên khách hàng được ghi theo yêu cầu của khách hàng.

**Quatest 1** TỔNG CỤC TIÊU CHUẨN ĐO LƯỜNG CHẤT LƯỢNG  
Directorate for Standards Metrology and Quality  
TRUNG TÂM KỸ THUẬT TIÊU CHUẨN ĐO LƯỜNG CHẤT LƯỢNG 1  
Quality Assurance and Testing Center 1

Trụ sở chính: 55 B Hoàng Quốc Việt,  
Cầu Giấy - Hà Nội  
Tel: (024) 38361399 - Fax: (024) 38361199  
Email: www.qltest1.com.vn  
Cơ sở 2: Khu CN Nam Thăng Long,  
Độc lập - Hà Nội  
Tel: (024) 32191022 - Fax: (024) 32191021

Số No.: 241/TKM/0293\_2 Trang/Pag.: 4/4

### KẾT QUẢ THỬ NGHIỆM

TEST RESULT

1. Tên mẫu thử/Sample: **GÓI ĐÓ THÉP STEEL SHOE**  
2. Khách hàng/Customer: **THÉP TÂM DÀY 8mm - NHÀ SẢN XUẤT: PRODETECH**  
3. Số lượng mẫu/Quantity: 01  
4. Tình trạng mẫu/Observation: Xem ảnh kèm theo  
5. Ngày nhận mẫu/Reception date: 19/02/2024  
6. Thời gian thử nghiệm/Time duration: 21/02/2024  
7. Ngày hoàn thành/Completion Date: 21/02/2024

TT Items	TÊN CHỈ TIÊU Specifications	P. PHÁP THỬ Test methods	M. QUY ĐỊNH Requirements	KẾT QUẢ Results	
1	• Giới hạn chảy Yield strength	MPa	JIS Z2241 : 2022	≥ 245	342
	• Độ bền kéo Tensile strength		400 - 510	464	
	• Độ giãn dài Elongation	%	≥ 17	32	



Hà Nội, ngày 22/02/2024  
P. TRƯỞNG PHÒNG THỬ NGHIỆM CƠ KHÍ - VLXD  
Head of Mechanical and Construction Material testing lab.

Nguyễn Văn Minh  
PHÓ GIÁM ĐỐC  
Nguyễn Ngọc Châm

1. Phiếu kết quả này chỉ có giá trị đối với mẫu thử do khách hàng đưa tới.  
This test result is valid only for samples taken by customer.  
2. Không được trích sao một phần kết quả này nếu không được sự đồng ý của trung tâm KỸ THUẬT 1.  
This test results shall not be reproduced except in full, without the written approval of QUATEST 1.  
3. Tên mẫu và tên khách hàng được ghi theo yêu cầu của khách hàng.

**Quatest 1** TỔNG CỤC TIÊU CHUẨN ĐO LƯỜNG CHẤT LƯỢNG  
Directorate for Standards Metrology and Quality  
TRUNG TÂM KỸ THUẬT TIÊU CHUẨN ĐO LƯỜNG CHẤT LƯỢNG 1  
Quality Assurance and Testing Center 1

Trụ sở chính: 55 B Hoàng Quốc Việt,  
Cầu Giấy - Hà Nội  
Tel: (024) 38361399 - Fax: (024) 38361199  
Email: www.qltest1.com.vn  
Cơ sở 2: Khu CN Nam Thăng Long,  
Độc lập - Hà Nội  
Tel: (024) 32191022 - Fax: (024) 32191021

Số No.: 241/TKM/0293\_3 Trang/Pag.: 4/4

### KẾT QUẢ THỬ NGHIỆM

TEST RESULT

1. Tên mẫu thử/Sample: **GÓI ĐÓ THÉP STEEL SHOE**  
2. Khách hàng/Customer: **THÉP TÂM DÀY 10mm - NHÀ SẢN XUẤT: PRODETECH**  
3. Số lượng mẫu/Quantity: 01  
4. Tình trạng mẫu/Observation: Xem ảnh kèm theo  
5. Ngày nhận mẫu/Reception date: 19/02/2024  
6. Thời gian thử nghiệm/Time duration: 21/02/2024  
7. Ngày hoàn thành/Completion Date: 21/02/2024

TT Items	TÊN CHỈ TIÊU Specifications	P. PHÁP THỬ Test methods	M. QUY ĐỊNH Requirements	KẾT QUẢ Results	
1	• Giới hạn chảy Yield strength	MPa	JIS Z2241 : 2022	≥ 245	310
	• Độ bền kéo Tensile strength		400 - 510	440	
	• Độ giãn dài Elongation		≥ 17	27	



Hà Nội, ngày 22/02/2024  
P. TRƯỞNG PHÒNG THỬ NGHIỆM CƠ KHÍ - VLXD  
Head of Mechanical and Construction Material testing lab.

Nguyễn Văn Minh  
PHÓ GIÁM ĐỐC  
Nguyễn Ngọc Châm

1. Phiếu kết quả này chỉ có giá trị đối với mẫu thử do khách hàng đưa tới.  
This test result is valid only for samples taken by customer.  
2. Không được trích sao một phần kết quả này nếu không được sự đồng ý của trung tâm KỸ THUẬT 1.  
This test results shall not be reproduced except in full, without the written approval of QUATEST 1.  
3. Tên mẫu và tên khách hàng được ghi theo yêu cầu của khách hàng.

**Quatest 1** TỔNG CỤC TIÊU CHUẨN ĐO LƯỜNG CHẤT LƯỢNG  
Directorate for Standards Metrology and Quality  
TRUNG TÂM KỸ THUẬT TIÊU CHUẨN ĐO LƯỜNG CHẤT LƯỢNG 1  
Quality Assurance and Testing Center 1

Trụ sở chính: 55 B Hoàng Quốc Việt,  
Cầu Giấy - Hà Nội  
Tel: (024) 38361399 - Fax: (024) 38361199  
Email: www.qltest1.com.vn  
Cơ sở 2: Khu CN Nam Thăng Long,  
Độc lập - Hà Nội  
Tel: (024) 32191022 - Fax: (024) 32191021

Số No.: 241/TKM/0293\_4 Trang/Pag.: 4/4

### KẾT QUẢ THỬ NGHIỆM

TEST RESULT

1. Tên mẫu thử/Sample: **GÓI ĐÓ THÉP STEEL SHOE**  
2. Khách hàng/Customer: **THÉP TÂM DÀY 12mm - NHÀ SẢN XUẤT: PRODETECH**  
3. Số lượng mẫu/Quantity: 01  
4. Tình trạng mẫu/Observation: Xem ảnh kèm theo  
5. Ngày nhận mẫu/Reception date: 19/02/2024  
6. Thời gian thử nghiệm/Time duration: 21/02/2024  
7. Ngày hoàn thành/Completion Date: 21/02/2024

TT Items	TÊN CHỈ TIÊU Specifications	P. PHÁP THỬ Test methods	M. QUY ĐỊNH Requirements	KẾT QUẢ Results	
1	• Giới hạn chảy Yield strength	MPa	JIS Z2241 : 2022	≥ 245	349
	• Độ bền kéo Tensile strength		400 - 510	453	
	• Độ giãn dài Elongation	%	≥ 17	29	



Hà Nội, ngày 22/02/2024  
P. TRƯỞNG PHÒNG THỬ NGHIỆM CƠ KHÍ - VLXD  
Head of Mechanical and Construction Material testing lab.

Nguyễn Văn Minh  
PHÓ GIÁM ĐỐC  
Nguyễn Ngọc Châm

1. Phiếu kết quả này chỉ có giá trị đối với mẫu thử do khách hàng đưa tới.  
This test result is valid only for samples taken by customer.  
2. Không được trích sao một phần kết quả này nếu không được sự đồng ý của trung tâm KỸ THUẬT 1.  
This test results shall not be reproduced except in full, without the written approval of QUATEST 1.  
3. Tên mẫu và tên khách hàng được ghi theo yêu cầu của khách hàng.

# F. Material CO -CQ



**ORIKEN POLYURETHANES Sdn Bhd** (618999-H)  
 Unit 1009, Block B, Phileo Damansara II  
 No. 15 Jalan 16/11, Off Jalan Damansara  
 46350 Petaling Jaya  
 Selangor Darul Ehsan, Malaysia  
 Telephone +603 7957 0633  
 Facsimile +603 7957 8533

REF : ORIKEN/5047/2022 DATED 21 MARCH 2022

SALES CONTRACT NO. : CONTRACT/2556/2022

**CERTIFICATE OF ANALYSIS**

QC DATE: 21/03/2022

**Customer** : HUYNH THIEN PHAT CO.,LTD.  
**Product** : ORITHANE RG4621  
**Batch No** : RG4621 - 2103221208  
**Delivered Quantity** : 13,200 KGS  
**Manufacturing Date** : 21/03/2022  
**Expiry Date** : 21/09/2022

**TEST RESULTS\***

Parameter	Result	Specification	*Cup Foam Test conducted under controlled laboratory conditions. Ambient temperature: 25°C MDI temperature: 20°C Polyol temperature: 20°C P : 141B : I Ratio: 100 : 15.5 : 138.6 Mixing Speed: 3,000rpm
Cream Time (sec)	35	35 ± 2	
String Time (sec)	200	190 ± 10	
Free Rise Density (kg/m <sup>3</sup> )	41.3	40 ± 2	

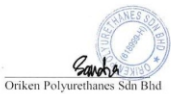

**TOSOH CORPORATION**  
 31-89000976847-0065  
 3-8-2, Shiba Minato-ku Tokyo 106-8623 JAPAN

March 17, 2022

**Certificate of Analysis**

This is to certify that we have performed the analysis of the product below:

**Product** : MILLIONATE MR-200  
**Lot No.** : 9764  
**Analysis Date** : February 24, 2022

Item	Unit	Specification	Result of Analysis
APPEARANCE		: brownish liquid	On standards
NCO CONTENT	%	: 30.5 < ~ <= 32.0	31.1
ACIDITY (as HCl)	%	: max. 0.04	mix. 0.01
VISCOSITY (25°C)	mPa.s	: 150 < ~ < 250	175
SPECIFIC GRAVITY (25/4°C)		: 1.220 < ~ <= 1.240	1.232

This certificate is issued electronically and it is valid without a signature.

H. Takada  
 General Manager  
 Isocyanates Department  
 Urethane Division

PREVIEW

1. Goods consigned from (Exporter's business name, address, country) ORIKEN POLYURETHANES SDN BHD UNIT 1009, BLOCK B, PHILEO DAMANSARA II NO.15, JALAN 16/11, OFF JALAN DAMANSARA 46350 PETALING JAYA SELANGOR, DARUL EHSAN, MALAYSIA			Reference No. KL-202203-CCF-618999-H-030469		
2. Goods consigned to (Consignee's name, address, country) HUYNH THIEN PHAT CO. LTD. 35A TL 51 THANH LOC 12 DISTRICT HO CHI MINH CITY, VIETNAM			ASEAN TRADE IN GOODS AGREEMENT/ ASEAN INDUSTRIAL COOPERATION SCHEME CERTIFICATE OF ORIGIN (Combined Declaration and Certificate)  FORM D Issued in MALAYSIA (Country) (See Overleaf Notes)		
3. Means of transport and route (as far as known)  Departure Date: 25 March 2022 by MARITIME TRANSPORT  Vessel's Name/Aircraft, etc.: WAN HAI 263 V2326  Port of Discharge: HO CHI MINH CITY			4. For official use  <input type="checkbox"/> Preferential Treatment Given Under ASEAN Trade in Goods Agreement  <input type="checkbox"/> Preferential Treatment Given Under ASEAN Industrial Cooperation Scheme  <input type="checkbox"/> Preferential Treatment Not Given (Please state reason/s)  Signature of Authorised Signatory of the Importing Country		
5. Item number	6. Marks and numbers on packages	7. Number and type of packages, description of goods (including quantity where appropriate and HS number of the importing country)	8. Origin criteria (see Overleaf Notes)	9. Gross weight or other quantity and value (FOB) where RVC is applied	10. Number and date of invoices
1.	VIET NHAT ORIKEN/5047/2022 VIETNAM	80 DRUM ORITHANE RG4621 TWENTY FOOT CONTAINER IMPORTING COUNTRY HS CODE 3402190000	RVC 93.8%	19040 KILOGRAM	ORIKEN/5047/2022
			TOTAL:	19040 KILOGRAM GROSS WEIGHT	
Page 1 of 1					
11. Declaration by the exporter The undersigned hereby declares that the above details and statement are correct; that all the goods were produced in MALAYSIA (Country) and that they comply with the origin requirements specified for these goods in the ASEAN Trade in Goods Agreement for the goods exported to VIETNAM (Importing Country) SELANGOR, 25 March 2022 Place and date, signature of authorised signatory			12. Certification It is hereby certified, on the basis of control carried out, that the declaration by the exporter is correct.  for Secretary General Ministry of International Trade and Industry Malaysia Kuala Lumpur, 29 March 2022 [CPT-CCF-W-220325-KL-00021-4] Place and date, signature and stamp of certifying authority		
13. <input type="checkbox"/> Third-Country Invoicing <input type="checkbox"/> Accumulation <input type="checkbox"/> Back-to-Back CO <input type="checkbox"/> Partial Cumulation			<input type="checkbox"/> Exhibition <input type="checkbox"/> De Minimis <input checked="" type="checkbox"/> Issued Retroactively		

Number of page 1 / 1

1. Goods consigned from (Exporter's name, address, country) Toosh Corporation 4560, Kaikei-cho, Shunan-shi, Yamaguchi 746-8501 JAPAN			Reference No. 210258237179601991 THE AGREEMENT ON COMPREHENSIVE ECONOMIC PARTNERSHIP AMONG MEMBER STATES OF THE ASSOCIATION OF SOUTHEAST ASIAN NATIONS AND JAPAN (AJCEP AGREEMENT) CERTIFICATE OF ORIGIN FORM AJ Issued in Japan		
2. Goods consigned to (Importer's/Consignee's name, address, country) HUYNH THIEN PHAT CO., LTD			4. For Official Use  <input type="checkbox"/> Preferential Treatment Given Under AJCEP Agreement  <input type="checkbox"/> Preferential Treatment Not Given (Please state reason/s)  Signature of Authorised Signatory of the Importing Country		
3. Means of transport and route (as far as known)  Shipment date March 19, 2022  Vessel's name/Aircraft etc.: PACIFIC TIANLIN 2210W  Port of discharge HOCHIMINH CITY PORT IN VIETNAM			6. Preference criteria (see Overleaf Notes)		
5. Item number (as necessary); Marks and numbers of packages; Number and kind of packages; Description of goods (including quantity where appropriate and HS number of the importing party at 6-digit level)			7. Quantity (gross or net weight or other quantity)	8. Number and date of invoices	
1): MILLIONATE MR-200 (POLYMETHYLENE POLYPHENYL POLYISOCYANATE) 306030			20 KGS	22030123 March 19, 2022	
Remarks and numbers: VARIOUS MARK MILLIONATE MR-200 (MDI) NET 250 KGS JAPAN					
Number and kind of packages: 80 DRUMS					
9. Remarks: TOYOTA TSUSHO ASIA PACIFIC PTE LTD 620 NORTH BRIDGE ROAD #19-01 PARKVIEW SQUARE, SINGAPORE 188778 <input checked="" type="checkbox"/> Third Country Invoicing <input checked="" type="checkbox"/> Issued Retroactively			11. Declaration by the exporter The undersigned hereby declares that the above details and statements are correct; that all the goods were produced in Japan and that they comply with the requirements specified for these goods in the AJCEP Agreement for the goods exported to VIETNAM. Place and date Tokyo, March 29, 2022 Printed name Hiroasa Arani Signature Company of authorised signatory		
10. Declaration by the exporter The undersigned hereby declares that the above details and statements are correct; that all the goods were produced in Japan and that they comply with the requirements specified for these goods in the AJCEP Agreement for the goods exported to VIETNAM. Place and date Tokyo, March 30, 2022 Printed name Masako Uchida Signature Stamp			11. Certification It is hereby certified, on the basis of control carried out, that the declaration by the exporter is correct. Competent Governmental Authority or Designee: The Japan Chamber of Commerce and Industry Place and date Tokyo, March 30, 2022 Printed name Masako Uchida Signature Stamp		

# G. ACTUAL PRODUCTION PHOTOS

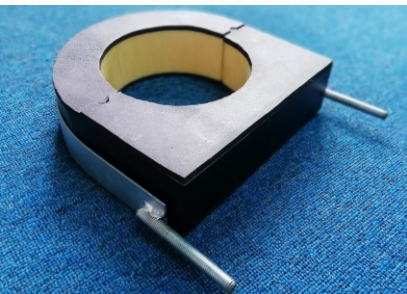
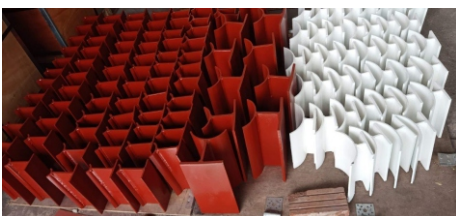
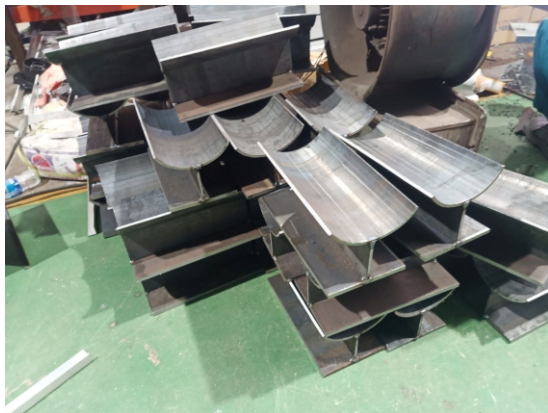

# TYPICAL PROJECT LIST



SAMSUNG THAI NGUYEN



FOXCONN BAC GIANG



LOTTE VO CHI CONG



LGH3 HAIPHONG



HAN JARDIN



PAIHONG - BINH DUONG



CHADWICK - INTERNATIONAL SHOOL



HANA MICRON BAC GIANG



MAYFAIR HAI DUONG



SUNNY OPTECH - HAI PHONG



## TYPICAL PROJECT LIST

No	The Name of construction	Time	Location
1	Foxconn FUYU 501, FUYU 88	2020	Bac Giang
2	Foxcon F15, F16, F17, F12	2021	Bac Giang
3	Foxconn M03, M08, M09, M10	2021	Bac Giang
4	Foxconn T01, T02, T03, T08, T09, T10	2023	Bac Giang
5	Foxconn A01,A02, A03, A21, A11, B42, B21	2023-2024	Bac Giang
6	Foxconn B06, B08, B09, B10 , B11, B12, B13, B21	2023 - 2024 - 2025	Bắc Giang



## TYPICAL PROJECT LIST

No	The Name of construction	Time	Location
7	SLP Park Yen Phong Factory	2022	Bac Ninh
8	SLP Park Bac A Factory	2022	Long An
9	Lux - Share ITC Factory	2022-2023	Bac Giang
10	Hana Micron Vina 1 Factory	2022 - 2023	Bac Giang
11	Idemitsu Vietnam Factory	2022-2023	Binh Dinh
12	Lotte Mall Tay Ho	2022-2023	Hanoi
13	Cicor Vietnam Factory	2022-2023	Binh Duong
14	Viessmann Factory	2022-2023	Dong Nai
15	DBG Factory	2022-2023	Thai Nguyen
16	Sumida Factory	2022-2023	Quang Ngai
17	Brighton College Vietnam	2022-2023	Ha Noi



## TYPICAL PROJECT LIST

No	The Name of construction	Time	Location
18	<b>Goertek Bắc Ninh</b>	2023 -2024	Bac Ninh
19	<b>Goertek Nghệ An</b>	2024	Nghệ An
20	<b>Luxvision Nghệ An</b>	2024	Nghệ An
21	<b>Luxtech - Nghệ An</b>	2024	Nghệ An
22	<b>Luxshare Nghệ An</b>	2024	Nghệ An
23	<b>Luxshare Bắc Giang</b>	2024	Bắc Giang
24	<b>LIKAI Nghệ An</b>	2024 -2025	Nghệ An
25	<b>RUNERGY Nghệ An</b>	2024	Nghệ An



## TYPICAL PROJECT LIST

No	The Name of construction	Time	Location
26	Nhà máy Juteng Nghệ An	2024	Nghệ An
27	Nhà máy Simona Ninh Bình	2024	Ninh Bình
28	Nhà máy Sunny Nghệ An	2024	Nghệ An
29	Nhà máy Hengwei	2024	Hải Phòng
30	Nhà máy Deli	2024	Hải Dương
31	Nhà máy Tripod	2024	Biên Hoà
32	Nhà máy Mercurie	2024	Tây Ninh
33	Nhà máy SI - FLEX	2024	Bac Giang
34	Nhà máy LOTUS	2024	Ninh Bình
35	Aptech Factory	2023	Hai Phong
36	Nam Chau Factory	2022	Bac Giang
37	Kangaroo Hung Yen Factory	2023	Hung Yen
38	Siba	2023	Vung Tau
39	TLB Yen Phong	2023	Bac Ninh



# PRODeTECH<sup>®</sup>

**M&E Materials Manufacture**

[www.Prodotech.vn](http://www.Prodotech.vn)



**CÔNG TY TNHH MTV PRODETECH  
PRODETECH ONE MEMBER CO., LTD**

Địa chỉ : Nhà B5-20 Vinhomes Gardenia Hàm Nghi, P. Cầu Diễn, Q. Nam Từ Liêm, TP Hà Nội

Nhà máy : Thôn 5, Xã Phú Cát, Huyện Quốc Oai, TP Hà Nội

Website : [www.prodotech.vn](http://www.prodotech.vn)

Email : [info@prodotech.vn](mailto:info@prodotech.vn)

Hotline : 0913 5540 030